

# Semiannual Roof Maintenance Inspection Checklist

Facility \_\_\_\_\_

Date \_\_\_\_\_

Location \_\_\_\_\_

Inspected by \_\_\_\_\_

## INSPECTION MATERIALS CHECKLIST

- |                                               |                                         |                                                              |                                                   |                                             |
|-----------------------------------------------|-----------------------------------------|--------------------------------------------------------------|---------------------------------------------------|---------------------------------------------|
| <input type="checkbox"/> Clipboard            | <input type="checkbox"/> Whisk broom    | <input type="checkbox"/> Screw driver                        | <input type="checkbox"/> Stiff wire brush         | <input type="checkbox"/> Scissors           |
| <input type="checkbox"/> Camera and film      | <input type="checkbox"/> Flashlight     | <input type="checkbox"/> Tool bag                            | <input type="checkbox"/> Claw hammer              | <input type="checkbox"/> Work gloves        |
| <input type="checkbox"/> Spray paint (bright) | <input type="checkbox"/> Roof mastic    | <input type="checkbox"/> Primer and brush                    | <input type="checkbox"/> Measuring tape           | <input type="checkbox"/> Reinforcement tape |
| <input type="checkbox"/> Sharp knife          | <input type="checkbox"/> Pointed trowel | <input type="checkbox"/> Plastic for elasto/<br>plastic room | <input type="checkbox"/> Rope with<br>safety clip |                                             |

## INSPECTION TASK CHECKLIST

	OK	Problem		Observation	Date of Repair
		Minor	Major		
I. Supporting structure					
Exterior and Interior Walls					
Expansion/contraction					
Settlement cracks					
Deterioration					
Moisture stains					
Physical damage					
Other					
Exterior and Interior Roof Deck					
Securement to supports					
Expansion/contraction					
Structural deterioration					
Water Stains					
Physical damage					
Attachment of felt/insulation					
New equipment/alterations					
Other					
II. Roof Condition					
General Appearance					
Debris					
Drainage					
Physical damage					
General Condition					
New equipment/alterations					
Other					
Surface Condition					
Base spots in gravel					
Alligatoring/cracking					
Slippage					
Other					
Membrane Condition					
Blistering					
Splitting					
Ridging					
Fishmouthing					
Loose felt laps					
Punctures					
Securement to substrate					
Fasteners					
Membrane slippage					
Other					

	OK	Problem		Observation	Date of Repair
		Minor	Major		
III. Flashing Condition					
Base Flashing					
Punctures					
Deterioration					
Blistering					
Open laps					
Attachment					
Ridging or wrinkling					
Other					
Counter Flashing					
Open laps					
Punctures					
Attachment					
Rusting					
Fasteners					
Caulking					
Other					
Coping					
Open Fractures					
Punctures					
Attachment					
Rusting					
Drainage					
Fasteners					
Caulking					
Other					
Wall					
Mortar joints					
Spalling					
Movement cracks					
Other					
IV. Roof Edging/Fascia					
Splitting					
Securement					
Rusting					
Felt deterioration					
Fasteners					
Punctures					
Other					
V. Roof Penetrations					
Equipment Base Flashing					
Open laps					
Punctures					
Attachment					
Other					
Equipment Housing					
Counter flashing					
Open seams					
Physical damage					
Caulking					
Draining					
Other					
Equipment Operation					
Discharge of contaminants					
Excessive traffic wear					
Other					
Roof Jacks/Vents					
Attachment					
Physical damage					
Vents operable					
Other					
VI. Expansion Joint Covers					
Open joints					
Puncture/splits					
Securement					
Rusting					
Fasteners					
Other					
VII. Pitch Pans					
Fill material shrinkage					
Attachment					
Other					

Draw a rough sketch of the facility roof plan on this page. (See reverse side of this sheet for instructions.)

## INSTRUCTIONS FOR ROOF PLAN SKETCH

1. Draw rough sketch of facility roof plan on preceding page. (Sketch does not need to be drawn to scale.)
2. Note with arrow and letter code (as shown on sample below) major defects that require repairs beyond the scope of this inspection. See HBK MS-1, *Operation and Maintenance of Real Property* (Appendix 13-B, Guide Number P-20), for inspection procedures.
3. Use the key below to identify problem areas by letter code.
4. Forward a copy of this completed form to your Field Maintenance Office.

### KEY FOR ROOF PARTS

- A Ponded water
- B Skylight
- C Roof Drain
- D Vent pipe
- E Vent or fan
- F Ladder
- G Walkway
- H Hatch
- J Flag pole
- K Sign Support
- L Air-conditioning unit
- M Pitch pan
- N Chimney and flashing
- P Parapet or fire wall
- R Coping
- S Base flashing
- T Cap flashing
- U Expansion joint cover
- V Downspout & leader
- W Fascia and gravel stop
- X Roof vent

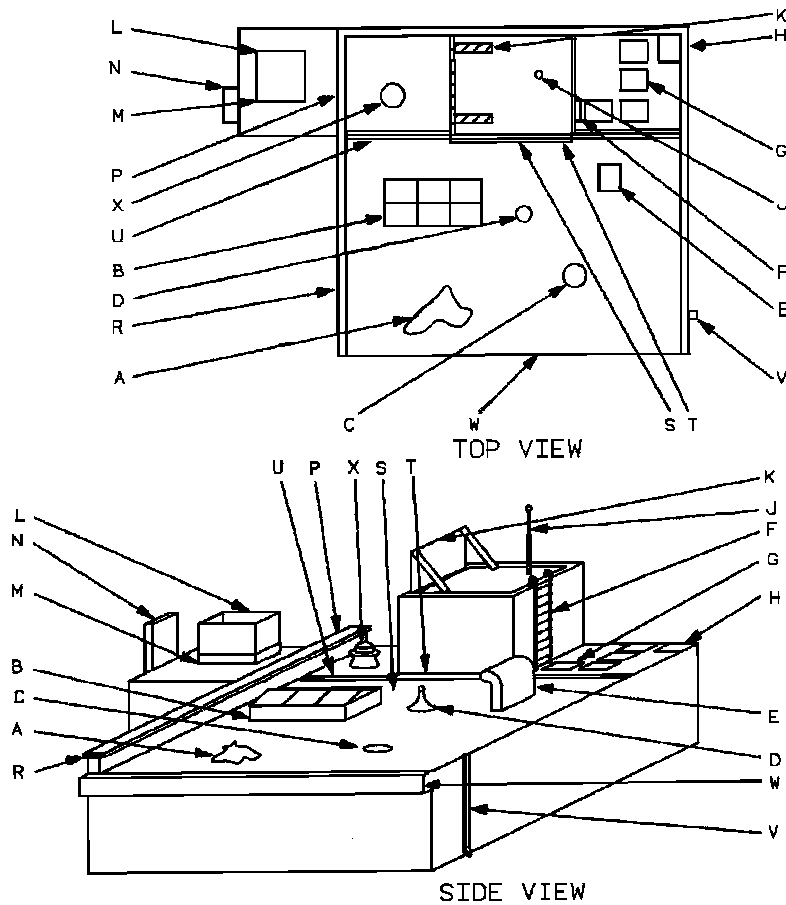

**SAMPLE SKETCHED ROOF PLAN**

MISC-ADA 1A66 I